



Bantam Lake and Watershed Monitoring Quality Assurance Project Plan

Prepared for the
Bantam Lake Protective Association
Morris, CT
January 11, 2023

This page has been intentionally left blank.

Bantam Lake and Watershed Monitoring Quality Assurance Project Plan

Prepared by
Aquatic Ecosystem Research, LLC
For the
Bantam Lake Protective Association
Morris, CT

January 1, 2023

This work was supported by the Connecticut Community
Foundation, Waterbury, CT [Grant #028898]



Approved by

Date

Constance Trolle, President BLPA

TABLE OF CONTENTS

Acronyms6

Distribution List7

Project Organization8

Introduction9

 Site Description9

 Water Quality History9

 History of Bantam TMDL and Watershed Based Plan10

 Project Description10

Lake Monitoring12

 Instrument Calibration12

 Field Equipment12

 Bottles13

 Labelling Sample Bottles14

 Chain of Custody14

 Monitoring Sites16

 Data and Water Sample Collections16

Watershed Monitoring19

 Instrument Calibration19

 Field Equipment19

 Bottles20

 Labeling Sample Bottles20

 Chain of Custody21

 Monitoring Sites21

 Whittlesey Brook Site23

 Bantam Lake Outlet24

 Little Pond Boardwalk25

 West Branch of Bantam River26

 Dog Pond Outlet27

 Bantam Pond Outlet28

 Data and Water Sample Collections29

Flow Estimate30

Laboratory Minimum Detection Limits and Quality Control and Assurances..... 35
References..... 36
Appendix A. Sample Bantam Lake Field Data Sheet..... 38
Appendix B. Sample Chain of Custody for Bantam Lake samples..... 39

ACRONYMS

AER	Aquatic Ecosystem Research, LLC
BLPA	Bantam Lake Protective Association
COC	Chain of Custody
CT DEEP	Connecticut Department of Energy and Environmental Protection
GPS	Global Positioning System
TMDL	Total Maximum Daily Loading

BANTAM LAKE AND WATERSHED MONITORING QAPP

DISTRIBUTION LIST

Traci Iott CT DEEP 79 Elm Street Hartford, CT Traci.iott@ct.gov	Larry Marsicano AER 25 Nutmeg Drive New Milford, CT lmarsicano@aerlimnology.com
Anne Murdica Bantam Lake Protective Association	Lukas Hyder White Memorial Foundation and Conservation Center
Connie Trolle Bantam Lake Protective Association	Mark Harris Town of Goshen Lakes Commission
Michael Doyle Town of Morris Inland Wetlands Commission Chair	Denise Raap Town of Litchfield First Selectman
Michael Jastremski Housatonic Valley Association	Monica Fulton
Dexter Kinsella Town of Goshen Selectman	Peter Longo Bantam Lake Protective Association
Elinor Carbone City of Torrington Mayor	Erick Bedan Watershed Management Program
James Fischer White Memorial Foundation and Conservation Center	Sarah Hurley CT DEEP
Susan Peterson CT DEEP Watershed Management Program	Jerry Abrahams Woodridge Lake Sewer District
Ted Donahue Litchfield Water Pollution Control Plant Superintendent	Jim Mersfelder Woodridge Lake Sewer District
Todd Carusillo Town of Goshen First Selectman	Jon Tarrant Town of Litchfield Selectman
Tom Stansfield Torrington Area Health District	Kathy Hill Bantam Lake Protective Association
Tom Weik Town of Morris First Selectman	

PROJECT ORGANIZATION

The Bantam Lake Protective Association (BLPA), Inc. is a private nonprofit (501(3)(C) organization devoted to the preservation of Bantam Lake and its surroundings. Working with the Town of Morris, The White Memorial Foundation, CT DEEP, and the Torrington Area Health Department, the BLPA strives to maintain the highest practical water quality for swimming, fishing, boating, and water and ice sports.

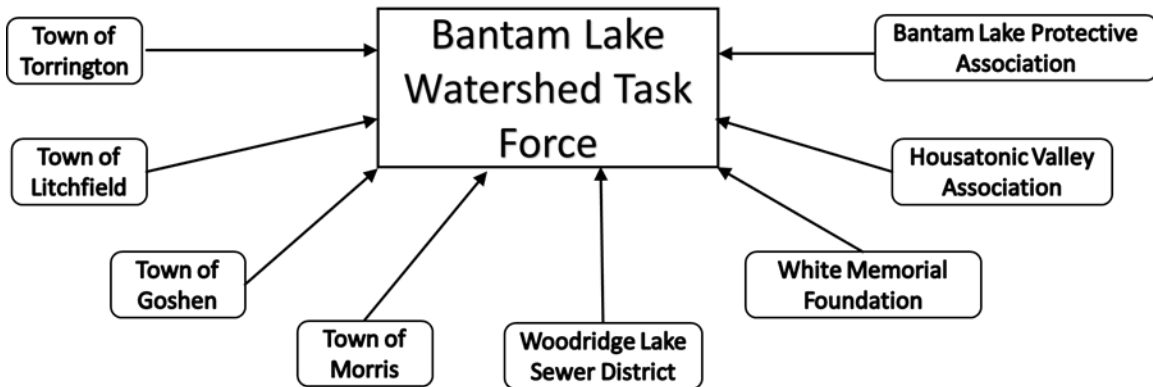

BLPA is coordinating efforts of the Bantam Lake Watershed Task Force which is comprised of five municipalities (Towns of Torrington, Litchfield, Goshen, Morris, and Woodridge Lake Sewer District) and three nonprofit organizations (White Memorial Foundation, Housatonic Valley Association, and Bantam Lake Protective Association).

The goal of the Bantam Lake Watershed Task Force is to create measurable improvements in water quality and aquatic habitat throughout the Bantam Lake Watershed.

Its objectives are:

To Coordinate and Monitor:

1. Best Management Practices
 - a. Structural
 - b. Public Information and Education
 - c. Land Conservation
 - d. Regulatory Tools
 - e. Institutional Practices
 - f. Agricultural Practice
2. Water Quality Monitoring
3. Adaptive Management

INTRODUCTION

Site Description

Bantam Lake is a 966-acre waterbody located in Towns of Litchfield and Morris, Connecticut and is the largest natural lake in the State. Geologically, the lake and watershed are situated in the Western Uplands of Connecticut (Bell 1985, Canavan & Siver 1995). That region has an erosion resistant, crystalline bedrock comprised of schists, gneiss, granite gneiss, and granofels (Healy & Kulp 1995). Surficial materials are glacial thin to thick till with moderate to well drainage soils and with a fragipan (hard pan) present on uplands (CTECO 2010, Stone et.al. 1992).

The watershed of Bantam Lake is 20,218 acres resulting in a large watershed to lake ratio of approximately 23 (Canavan & Siver 1995). In a 1995 survey, land use was characterized as mainly deciduous forest and agriculture lands with smaller areas of medium-density residential land use, wetlands, and coniferous forests (Healy & Kulp 1995). Much of the shoreline is lined with homes, beaches, and several camps. There is also open space along the northern shoreline, which is owned by the White Memorial Foundation.

Water Quality History

Earliest known assessments of Bantam Lake occurred in the late 1930s (Deevey 1940). That study and several others occurring over the next 70 years (Frink & Norvell 1984, Canavan & Siver 1994, 1995, Healy and Kulp 1995) included Bantam Lake as part of statewide surveys of Connecticut Lakes that used standard in-situ measurements and laboratory analyses of water samples to develop a water quality database. These studies resulted in important historical water quality baselines for many of Connecticut's lakes. Several of those statewide surveys have been compiled in Canavan and Siver (1994, 1995).

A paleolimnological study of Bantam Lake's water quality used statistically significant inference models and the remains of fossil bearing algae – layered chronologically in a sediment core – to estimate changes in water quality over time (e.g., trophic level, conductivity levels, and pH, over time; Siver 1993, Siver and Marsicano 1996). The oldest sediments in the Bantam sediment core dated back to *ca* 1857.

Based on the earliest fossil assemblages, Bantam Lake was oligotrophic to early mesotrophic from *ca* 1857 through *ca* 1898. Subsequently, the lake's trophic status changed; by *ca* 1926 Bantam Lake was mesotrophic. The lake became more eutrophic between *ca* 1946 and *ca* 1964. The fossil assemblages near the top of the core dated to *ca* 1991 and indicated that the lake was eutrophic.

Bantam Lake has continued to exhibit eutrophic characteristics resulting in the high levels of algal productivity that have become one of the primary management concerns of the BLPA. High concentrations of cyanobacteria and bloom-like conditions are common between the midsummer and fall periods of the recreational season. Bantam Lake was listed in CT DEEP's 2004 *Impaired Waters for Connecticut* (CT DEEP 2004) due to noxious aquatic plants and exotic species. However, by 2016 the lake was designated as impaired due to excess algal growth, chlorophyll-*a*, nutrient, eutrophication, and biological indicators (CT DEEP 2016).

History of Bantam TMDL and Watershed Based Plan

In fulfillment of the 1972 Clean Water Act, the CT DEEP developed water quality standards, monitored water quality of surface waters to assess consistency with those standards, and prioritized water resources not meeting standards for restoration efforts. Inland water resources not meeting standards were listed in the Connecticut Integrated Water Quality Report (e.g., CT DEEP 2020, 2022).

Part of the restoration efforts included the development of a *Connecticut Statewide Lake Nutrient Total Maximum Daily Load Core Document* (CT DEEP 2021a). This document listed the State's water quality standards, identified nutrient pollution sources to lakes, and established a planning process by which nutrient budgets for lakes could be established through *total maximum daily loading* (TMDL) analyses. In conjunction with a TMDL analyses, a *Watershed-Based Plan* to restore and bring those water resources within the standards would be developed.

The CT DEEP's initial effort for a TMDL study and Watershed Based Plan occurred at Bantam Lake. The Bantam TMDL report is found as Appendix 1 of the *Core Document* (see CT DEEP 2021b). That document identifies nutrient sources in the Bantam Lake watershed, as well as in the lake itself. It also provides high level recommendations for watershed-based restoration, that could be expanded and detailed in the Watershed-Based Plan. The Bantam Lake TMDL Report also provided recommendations on monitoring water quality in the lake and throughout the watershed. The monitoring program would serve to assess watershed-based efforts to restore water quality.

Project Description

Section 8 of Bantam TMDL Report provided recommendations for lake and watershed monitoring programs. Table 14 in the report, which summarized recommendations, is provided below. This document was developed to memorialize monitoring protocols to assure the quality of collected data and consistency in data collection methods.

Table 1. CT DEEP recommended monitoring parameters, frequencies, locations, and priority/status for Bantam Lake and watershed (CT DEEP 2021b, Table 14).

Parameters	Frequency	Location(s)	Priority / Status
Dissolved oxygen and temperature profiles, Secchi disk transparency readings	Bi-weekly (ideal) or monthly (minimum) from April-October	North Bay, Center Lake, and South Bay stations	High / Existing
Total phosphorus, total nitrogen	Monthly from April-October	North Bay, Center Lake, and South Bay stations at three depths (top, middle, bottom)	High / Existing
Chlorophyll-a	Monthly from April-October	North Bay, Center Lake, and South Bay stations in epilimnion (top to middle)	High / Add
Phytoplankton speciation	Monthly from April-October	North Bay, Center Lake, and South Bay stations in epilimnion (top to middle)	High / Add
Toxicity analysis	As needed during cyanobacteria bloom	North Bay, Center Lake, and South Bay stations in epilimnion (top to middle)	High / Add
Total phosphorus, total nitrogen, flow estimate	Monthly from April-October	Dog Pond outlet, Bantam Pond outlet, West Branch Bantam River, Little Pond outlet, and Whittlesey Brook outlet	High / Add
Total phosphorus, total nitrogen, total suspended solids, flow estimate	Before and after BMP construction	Above and below BMP site(s) for reference control and downstream test sites	Medium / Add
Dissolved oxygen, pH, <i>E. coli</i>	Monthly from April-October	Dog Pond outlet, Bantam Pond outlet, West Branch Bantam River, Little Pond outlet, and Whittlesey Brook outlet	Medium / Add
pH, color, alkalinity	Monthly from April-October	North Bay, Center Lake, and South Bay stations in epilimnion (top)	Medium / Add
Invasive species (visual surveys, boat inspections)	Annually	In-lake especially near boat ramps and other access points, and during boat inspections	High / Existing

LAKE MONITORING

Instrument Calibration

There are a several manufactures of water quality monitoring instrumentation, e.g., Yellow Springs Instruments, Hydrolab, and Eureka Water Probes. The multiprobe instrumentation is expensive to purchase, and repair if damaged, so it should be treated with great care. A manufacturer's inspection and calibration on a regularly scheduled basis (e.g., once every one to two years) is advisable. Regular calibrations for many of the parameters the multiprobe measures can be performed by the users following the manufacture's *User Guide/Manual*. Prior to each sampling date, the following calibrations should be performed: dissolved oxygen, conductivity, and pH. Carefully follow the instructions provided in the manual. Instructional videos are often available as well.

Field Equipment

- Global positioning system (GPS) to accurately locate the sampling sites on the lake.
- Metric field tape with weights secured to the end to measure the depth at each site.
- Secchi disk to measure water clarity / transparency. A wooden meter stick or metric field tape can be used to measure transparency, or the Secchi disk can be used attached to the end of a metric field tape.
- Water quality multiprobe instrumentation to measure temperature, dissolved oxygen, conductivity and specific conductance, and pH. Some equipment may have additional sensors, e.g., fluorimeters to measure algal photosynthetic pigments, oxidation-reduction potential, and turbidity. The probes are contained within a sonde or casing that is attached to a cable long enough to measure variables from ½ meter below the surface to ½ meter above the lake bottom.
- Some systems have on the other end of the cable a handheld display. In other systems, the cable attaches to a Blue-Tooth battery box that transmits data to a tablet or iPad that has the manufacturer's app installed. Data must be recorded by either manually writing it down on a paper (see Appendix A), or saving it on the tablet or iPad.
- A Van-Dorn Sampling Bottle is used to collect water samples at any depth within the water column. The bottle should be at the end of a line that has been marked with permanent marker at ½ meter (m), at 1m, and at each meter below that. The line should be threaded through a weighted messenger that will trigger the bottle-closing mechanism once the desired sampling depth is reached.

- Sample bottles (see below).
- Field notebook to recorded field data collected in the field. The notebook should also be used to catalog samples collected and their identifications. The notebook should be resistant preferably weather, e.g., Rite in the Rain All-Weather Universal (see www.riteintherain.com).
- Cooler to keep samples cold. The cooler should be partially filled with ice or cold packs to keep samples cold.

Bottles

The types and sizes of bottles for the parameters to be monitored will vary depending on the laboratory performing the analyses. Table 2 provides a list of bottles currently used for each sample collection date on Bantam Lake. Table 2 details sizes and colors of bottle, what will be analyzed in each bottle, and where to obtain those bottles.

Table 2. Bottle types, sizes (Volumes), quantity (No.), what will be analyzed in a bottle (Parameters), and where the bottles can be obtained (Source).

Type	(Volume)	No.	Parameters	Source
Wide mouth, translucent plastic	32 oz. / 1000 mL	3	Chlorophyll-a	York Analytical
Wide mouth, translucent plastic	16 oz. / 500 mL	9	pH, Alkalinity, Ammonia, Nitrate/Nitrite, Total Kjeldahl Nitrogen, Total Phosphorus	York Analytical
Wide mouth, amber plastic	16 oz. / 500 mL	3	Phytoplankton enumerations	Aquatic Ecosystem Research
Amber vial	20 mL	1	Phytoplankton identifications	Aquatic Ecosystem Research
Sterile PETG Media Bottles	4 oz./ 125 mL	3	Microcystin	WCSU Wong Lab

Labelling Sample Bottles

Sample bottles should be clearly labelled with permanent black marker (e.g., with a Sharpie) directly on the sample bottle or on an adhesive label securely attached to the sample bottle. The labels should match the sample bottle identifications on the Chain of Custody (see below). Labels can be either descriptive (Fig. 1) or numeric. If numeric, a record of what each number corresponds to must be created prior to delivery of sample bottles to the laboratory.

Center Lake	South Bay	North Bay	Analytes
			<p><i>Chlorophyll-a</i> 1000mL bottles</p> <p>20mL Amber Vial Plankton net sample</p> <p>Sterile PETG Media Bottles for cyanotoxins</p>
			<p><i>Nutrients:</i> TKN, TN, Ammonia Nitrate, Nitrite Alkalinity 500mL bottles</p>
			<p><i>Algae (amber)</i> 500mL bottles</p>

Figure 1. Illustration of bottle types, sizes, numbers of bottles, and parameters to be analyzed in those bottles.

Chain of Custody

A Chain of Custody (COC) should be completed prior to each sampling event and a copy provided to the laboratory performing the analyses. A COC provides a record of what samples are being provided to the laboratory and what analyses you are requesting of the laboratory. Sample identifications on the COC should match the labels on the sample bottles. A template is provided in Appendix A. Work with the commercial laboratory to develop a COC for this part of the project.

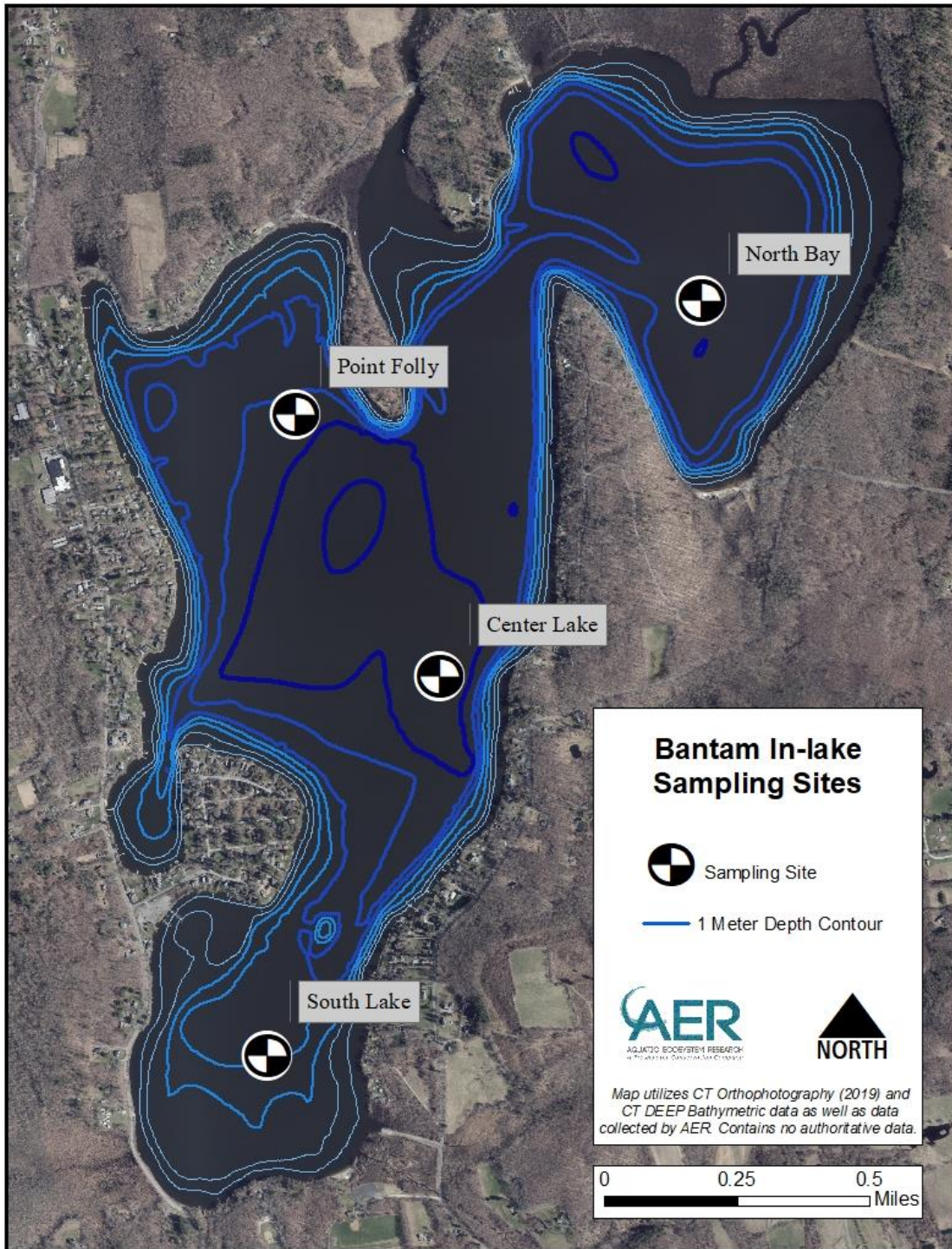

Figure 2. Map of the Bantam Lake monitoring sites.

Monitoring Sites

The Bantam Lake Watershed TMDL prescribes monitoring at three stations in the lake: North Bay, Center Lake, and South Bay (Fig. 2). Coordinates for each are provided in Table 3. Field data (see below), but not water samples, have historically been collected at a fourth site, Folly Point, which is also identified in Fig. 2 and Table 2. Coordinates should be uploaded into the GPS.

Table 3. Coordinates for monitoring sites on Bantam Lake

Site	Latitude	Longitude
North Bay	41.71087	-73.21155
Center Lake	41.70056	-73.22102
South Bay	41.70773	-73.22638
Folly Point	41.69015	-73.22728

Data and Water Sample Collections

For each sampling station, the following steps should be executed.

1. Navigate the boat to the field station and anchor. Be sure that the boat is securely anchored particularly on windy days. Use the metric field tape to measure the depth at that station. Lower the weighted end until it stops descending. Bring up any slack in the tape, grab the tape at the surface of the water, read the depth, and record the depth in the field notebook.
2. Measure Secchi disk transparency by lowering the Secchi disk down the water column until it is no longer visible. Raise the Secchi disk up until it is visible again. Slowly lower it to the exact distance where visual contact is lost. Measure from the point on the line at the surface of the water to the Secchi disk using the meter stick and record that length in the field notebook.
3. Prepare the multiprobe for use following the manufacturer's instructions. Lower the bottom of the sonde body, where the sensors in the multiprobe are located, to approximately



Figure 3. Top - Field tape to measure maximum depth at the site. Bottom – Secchi disk being lowered down the water column.

½ meter of depth. Record the depth, temperature, dissolved oxygen, percent oxygen saturation, conductivity and/or specific conductance, and pH. Lower the sonde again until the bottom is at 1m of depth and record that data. Repeat at every meter below that. The final depth should be ½ meter above the bottom of the lake. NOTE: Typically, the oxygen sensor requires some time to equilibrate at each depth. Be sure to allow for that time and the oxygen concentration reading is stable before recording that data.

4. Prepare and use the Van Dorn Sampling Bottle following the steps below:
 - a. Open the sampler by raising the stoppers.
 - b. Set the trip mechanism.
 - c. Lower the sampler to the desired depth.
 - d. Activate a metal or rubber messenger to "trip" the mechanism that closes the end seals of the sampler.
 - e. Transfer the water sample from the Van Dorn bottle to individual sample containers via the drain valve.

Samples will be collected at 1m of depth and at ½ meter above the bottom. It may be necessary to deploy the device to those depths two time to obtain enough water to fill the sets of bottles designated for each depth. Additional samples will be collected at a mid-depth level at the thermocline. The thermocline can be determined in the field by reviewing the temperature profile data and finding the two consecutive depths where the difference in temperature is greatest.

5. Step 5 is repeated at each of the three stations where water samples are collected for analyses and at the Folly Point station.

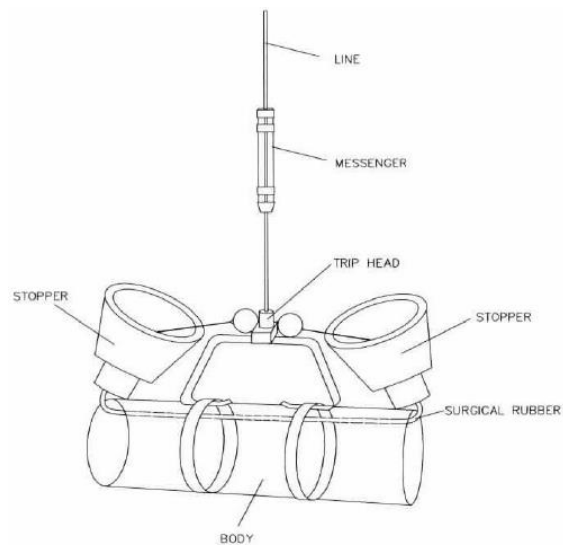

Figure 4. Labelled diagram (top) and photograph (bottom) of the Van Dorn Sampling Bottle.

6. Store all samples in the ice-filled cooler until they are delivered to the lab. Samples must be delivered to the laboratory within 24 hours of collections along with the completed Chain of Custody.

WATERSHED MONITORING

Instrument Calibration

The same monitoring instrumentation used in the lake, e.g., Yellow Springs Instruments, Hydrolab, and Eureka Water Probes, will be used at the watershed sites. As noted earlier, the multiprobe instrumentation is expensive to purchase, and repair if damaged, so it should be treated with great care. A manufacturer's inspection and calibration on a regularly scheduled basis (e.g., once every one to two years) is advisable. Regular calibrations for many of the parameters the multiprobe measures can be performed by the users following the manufacturer's *User Guide/Manual*. Prior to each sampling date, the following calibrations should be performed: dissolved oxygen, conductivity, and pH. Carefully follow the instructions provided in the manual. Instructional videos are often available as well.

Field Equipment

- Global positioning system to accurately locate the sampling sites on the lake.
- Water quality multiprobe instrumentation to measure temperature, dissolved oxygen, conductivity and specific conductance, and pH. Some equipment may have additional sensors, e.g., fluorimeters to measure algal photosynthetic pigments, oxidation-reduction potential, and turbidity. The probes are contained within sonde or casing that is attached to a cable long enough to measure variables from ½ meter below the surface to ½ meter above the lake bottom.
- Some systems have a on the other end of the cable a handheld display. In other systems, the cable attaches to a blue-tooth battery box that transmits data to a tablet or iPad with the manufacturer's app. Data must be recorded by either manually writing it down on a paper (see Appendix A) or saving it on the tablet or iPad.
- Sample bottles (see below).
- Field notebook to recorded field data collected in the field. The notebook should also be used to catalog samples collected and their identifications. The notebook should be resistant preferably weather, e.g., Rite in the Rain All-Weather Universal (see www.riteintherain.com).
- Cooler to keep samples cold. The cooler should be partially filled with ice or cold packs to keep samples cold.
- Adjustable Handle Water Sample Dipper. This is used to collect water sample from the shoreline.

- Hip waders to wade into the shallow shoreline areas. This will allow for use of multiprobe for data collection.

Bottles

The types and sizes of bottles for the parameters to be tested from samples collected in the watershed will vary depending on the laboratory performing the analyses. Parameters to be measured in the laboratory, as prescribed in the TMDL study, were total phosphorus, total nitrogen, total suspended solids, and *E. coli* levels.

Sample bottles for each site shall include:

- one 500 mL bottle (total of six 500 mL bottles for all sites),
- two 250 mL bottle (total of twelve 250 mL bottles for all sites), and
- one bacteria bottle (total of six 125 mL bottles for all sites)

Labeling Sample Bottles

Sample bottles should be clearly labelled with permanent black marker (e.g., with a Sharpie) directly on the sample bottle or on an adhesive label securely attached to the sample bottle. The labels should match the sample bottle identifications on the Chain of Custody (see below). Labels can be either descriptive (Fig. 2) or numeric. If numeric, a record of what each number corresponds to must be created prior to delivery of sample bottles to the laboratory.



Figure 5. Illustration of bottles and labelling for one site in the Bantam watershed. From L to R: 1-L bottle, 500mL bottle, 500mL bottle, 125 mL bacteria (*E. coli*) bottle.

Chain of Custody

A Chain of Custody (COC) should be completed prior to each sampling event and a copy provided to the laboratory performing the analyses. A COC provides a record of what samples are being provided to the laboratory and what analyses you are requesting of the laboratory. Sample identifications on the COC should match the labels on the sample bottles. A template is provided in Appendix A. Work with the commercial laboratory to develop a COC for this part of the project.

Monitoring Sites

Section 8 of the TMDL report recommended regular (monthly or bimonthly) monitoring of five sites in the watershed: Dog Pond outlet, Bantam Pond outlet, West Branch Bantam River, Little Pond outlet, and Whittlesey Brook outlet. An additional sixth site, the Bantam Lake Outlet, was added at the advisement of the BLPA.

Those six sites have been identified on a Bantam Lake watershed map below (Table 3; Fig. 5). Additional detail for each site has been provided on the pages that follow and include a map for each specific site, coordinates for each site in decimal degrees (e.g., 41.686403, -73.221073), and photographs from the area around the site.

Table 4

Site	Latitude	Longitude
Whittlesey Brook Site	41.686403	-73.221073
Bantam Lake Outlet	41.716801	-73.22217
Little Pond Boardwalk	41.812243	-73.234069
West Branch of Bantam River	41.788048	-73.218850
Dog Pond Outlet	41.812243	-73.234069
Bantam Pond Outlet	41.791967	-73.194457

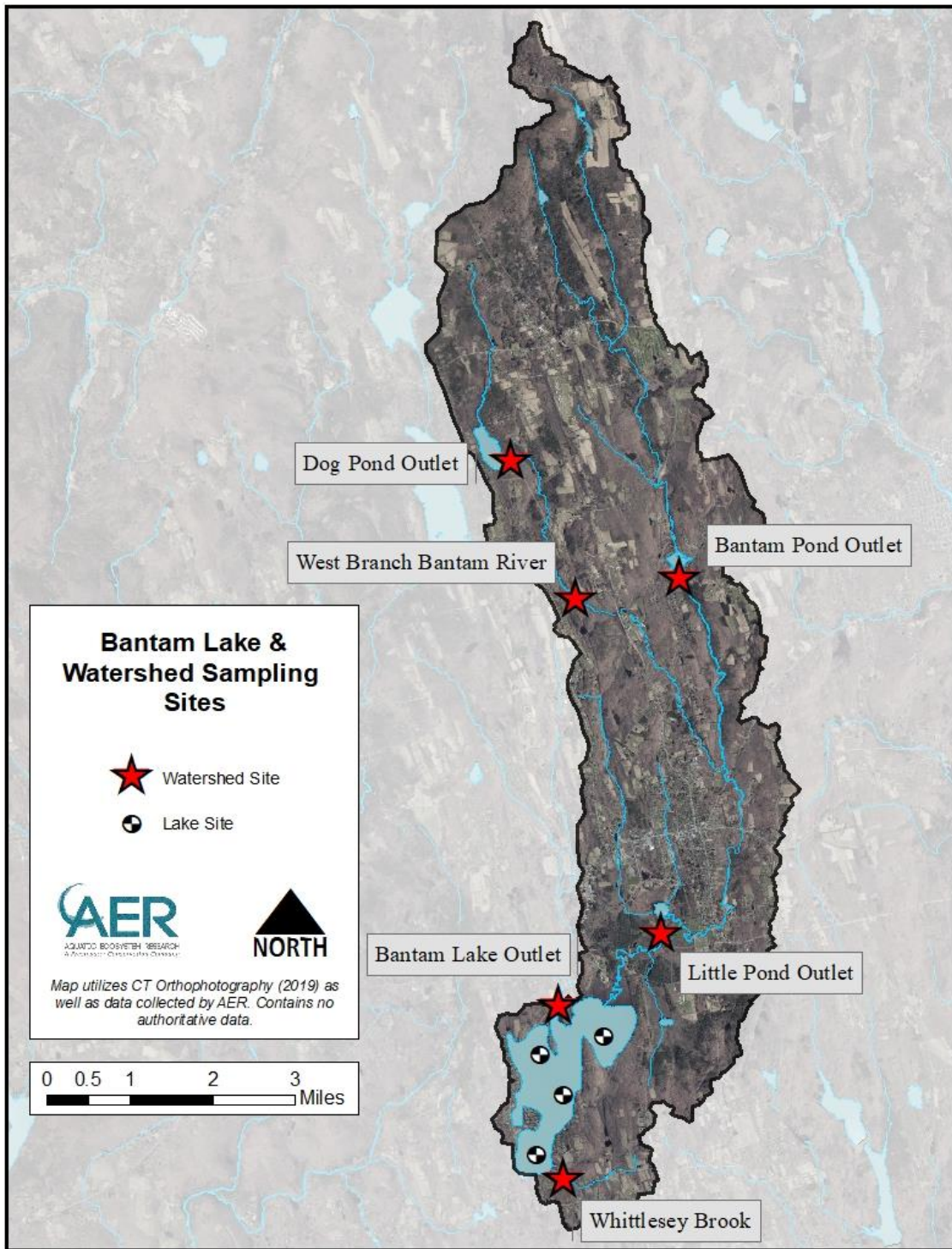

Figure 6. Map of the Bantam Lake watershed and the of the watershed sampling sites.

Whittlesey Brook Site



Bantam Lake Outlet



Little Pond Boardwalk

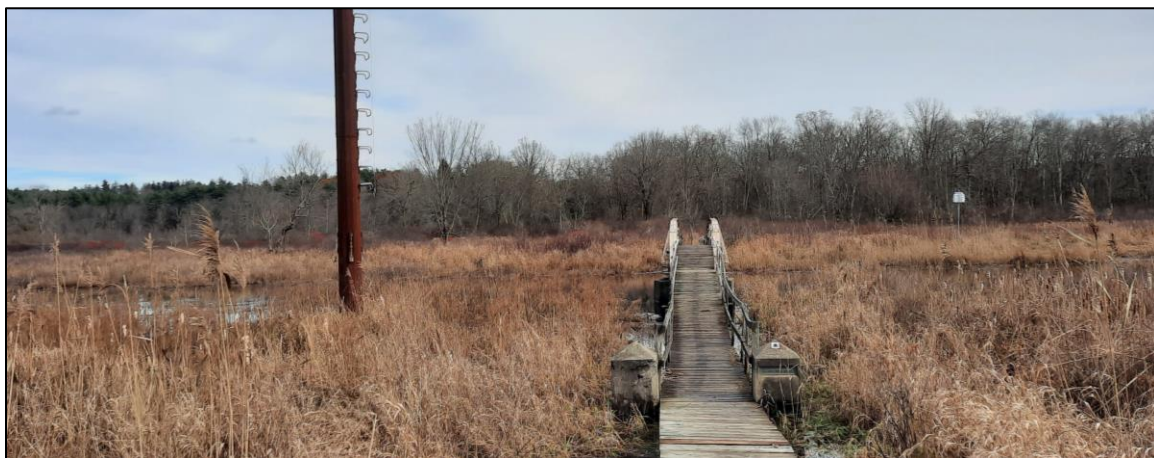
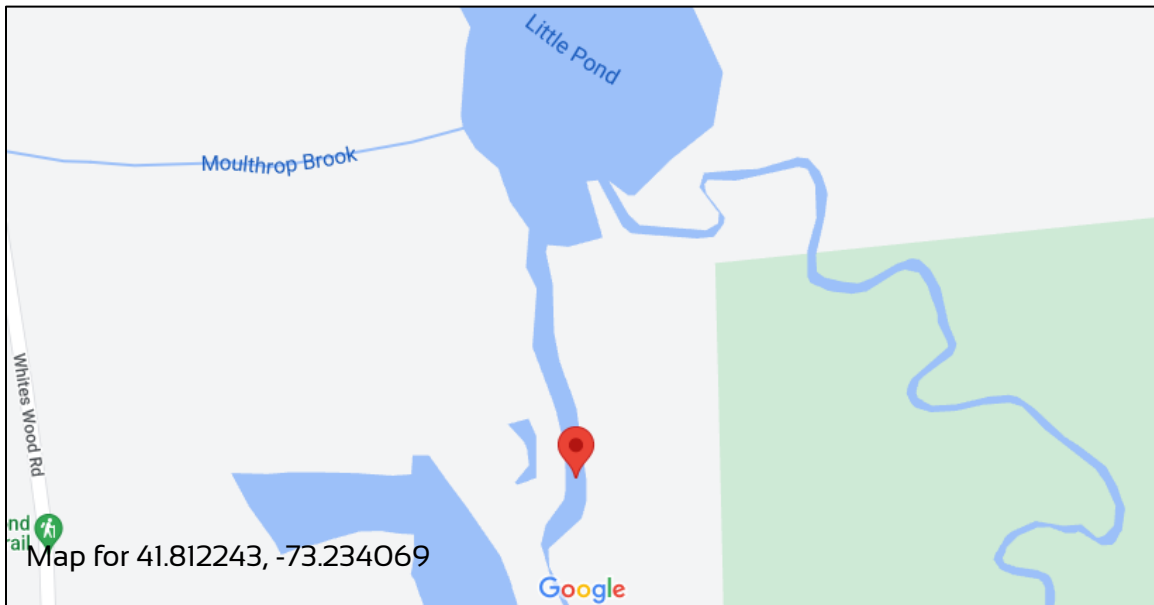

West Branch of Bantam River



Dog Pond Outlet



Bantam Pond Outlet

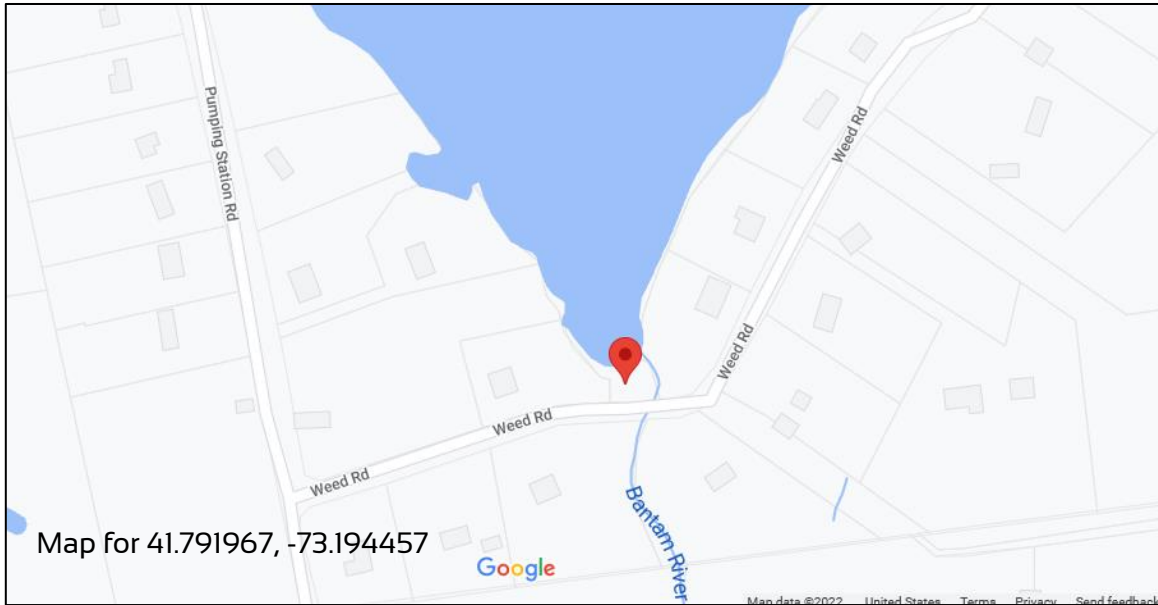

Data and Water Sample Collections

1. Coordinates should be uploaded into a GPS in advance.
2. Drive and park at a safe place near the site. Collect the equipment, instrumentation and bottles you will need. Lock the vehicle before walking to the site.
3. In the field notebook, record data, time, weather conditions, and flow characteristics, e.g., low flow, high flow.
4. With hip waders on, safely wade out into 1 to 2 feet of water with the multiprobe and record temperature, dissolved oxygen, conductivity, and pH.
5. After returning the multiprobe to the shoreline, wade back out with the adjustable handle water sample dipper. Extend the handle such that you are sampling as near to the center of the stream as possible. Collect water in the vessel at the end of the handle.
6. Return to the shore of the stream or outlet and transfer sample into the bottles prelabelled for that site.
7. Return to the car, store water samples in an ice-filled cooler, and carefully store the equipment and instrumentation.
8. After sampling is complete, use the surrogate watershed model to estimate flow at each site and record it.



Figure 7. Adjustable handle water sample dipper.

FLOW ESTIMATE

Water samples collected at the watershed sites will be analyzed to determine the concentrations of total phosphorus, total nitrogen, total suspended solids, and *E. coli* bacteria. To estimate the mass of the nutrients exported to Bantam Lake from the watershed or a portion of the watershed, the discharge rate, i.e., how much water is flowing, needs to be estimated. That generally requires stream gauging which does not exist in the Bantam watershed.

For this project discharge rate will be estimated using the *Watershed Area Ratio Method* and the nearby surrogate watersheds that are gauged, namely the Nepaug River watershed and the Bunnel Brook watershed. Both are located in Connecticut.

The date of sample collections from the Bantam Lake watershed should be recorded in the field notebook. For the following smaller Bantam watershed sites, the Bunnel Brook surrogate will be used: Whittlesey Brook, Dog Pond outlet, West Branch of the Bantam River, and Bantam Pond (Timber Pond) outlet. To estimate flow on a given day for the Whittlesey Brook watershed, perform the following:

1. Open the Bantam Watershed Discharge Excel spreadsheet. Click on the Whittlesey tab at the bottom. Then click on the link to the USGS Bunnel Brook Discharge Rate website.

Date	Bunnel Area (sq mi)	Whittlesey (sq mi)	Discharge Bunnel (ft3/sec)	Discharge Whittlesey (ft3/sec)
10-Dec-22	4.2	1.15		0.00
	4.2	1.15		0.00
	4.2	1.15		0.00
	4.2	1.15		0.00
	4.2	1.15		0.00
	4.2	1.15		0.00
	4.2	1.15		0.00
	4.2	1.15		0.00
	4.2	1.15		0.00

2. The top of the website will appear like the image below.

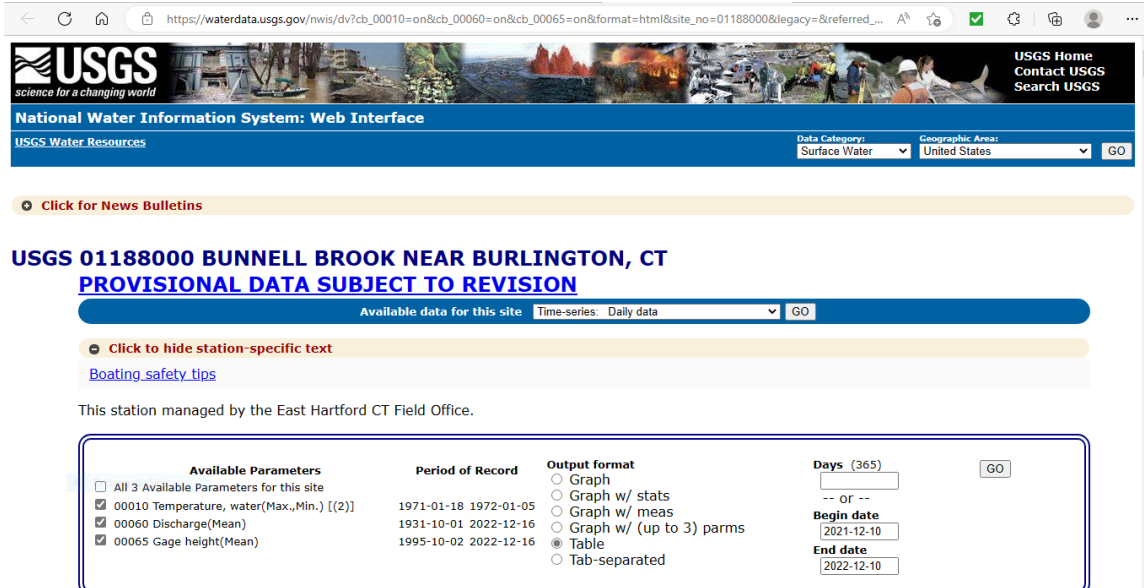

3. Click the arrow in the Date Column to sort the dates in descending order (most recent to oldest).

Date	Dis-charge, ft ³ /s, (Mean)
12/16/2022	22.0 ^P
12/15/2022	3.53 ^P
12/14/2022	4.35 ^P
12/13/2022	4.45 ^P
12/12/2022	4.46 ^P
12/11/2022	4.14 ^P
12/10/2022	4.55 ^P
12/09/2022	5.32 ^P
12/08/2022	9.03 ^P
12/07/2022	23.1 ^P

- Find the date in the table corresponding with the date the Whittlesey Brook site was sampled. For this example, we are using December 10, 2022 (discharge rate of 4.55 cubic feet per second). Record the discharge rate on the Excel spreadsheet. The discharge for the Whittlesey Brook watershed will be automatically calculated.

Date	Bunnel Area (sq mi)	Whittlesey (sq mi)	Discharge Bunnel (ft3/sec)	Discharge Whittlesey (ft3/sec)
10-Dec-22	4.2	1.15	4.55	1.25
	4.2	1.15		0.00
	4.2	1.15		0.00
	4.2	1.15		0.00
	4.2	1.15		0.00
	4.2	1.15		0.00
	4.2	1.15		0.00
	4.2	1.15		0.00

- The same steps will be taken for the Dog Pond Outlet, West Branch Bantam River, and Bantam Pond sites. Start by first clicking the appropriate tab on the bottom of the Watershed Discharge Excel spreadsheet.

22		4.2	1.15		0.00	
23						

[Whittlesey](#) | [W. Branch Bantam R.](#) | [Dog Pond](#) | [Bantam Pond](#) | [Little Pond](#) | [Banta](#)

- For the larger Little Pond watershed and Bantam Outflow sites, the USGS Nepaug River gauging station will be used. Click the Little Pond tab on the spreadsheet, and then the link to the Nepaug River gauging station.

1			23.4		25	
---	--	--	------	--	----	--

[Whittlesey](#) | [W. Branch Bantam R.](#) | [Dog Pond](#) | [Bantam Pond](#) | [Little Pond](#) | [Bantam O](#)

Date	Nepaug Area (sq mi)	Little Pond Outlet	Discharge Nepaug (ft3/sec)	Discharge Bantam Pond (ft3/sec)
10-Dec-22	23.4	25		0.00
	23.4	25		0.00
	23.4	25		0.00
	23.4	25		0.00
	23.4	25		0.00
	23.4	25		0.00
	23.4	25		0.00

7. The top of the website will appear like the image below.

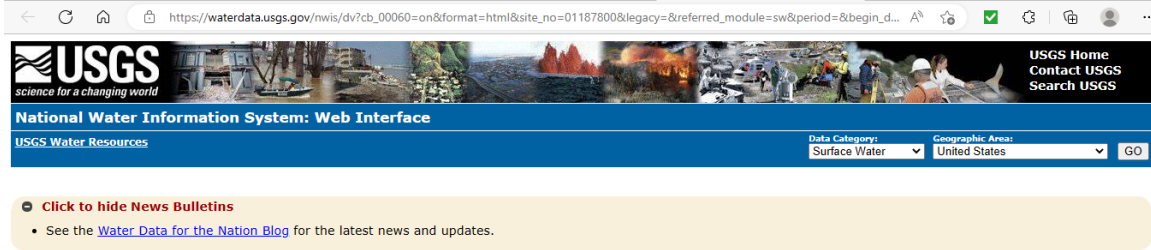

USGS 01187800 NEPAUG R NR NEPAUG, CT.
PROVISIONAL DATA SUBJECT TO REVISION

Available data for this site Time-series: Daily data GO

Available Parameters <input type="checkbox"/> All 1 Available Parameters for this site <input checked="" type="checkbox"/> 00060 Discharge(Mean)	Period of Record 1921-10-01 2022-12-16	Output format <input type="radio"/> Graph <input type="radio"/> Graph w/ stats <input type="radio"/> Graph w/ meas <input type="radio"/> Graph w/ (up to 3) parms <input checked="" type="radio"/> Table <input type="radio"/> Tab-separated	Days (365) -- or -- Begin date 2021-12-10 End date 2022-12-10
---	--	---	---

8. Find the appropriate discharge rate based on the date (for this example, December 10, 2022).

DATE	Dec 2021	Jan 2022	Feb 2022	Mar 2022	Apr 2022	May 2022	Jun 2022	Jul 2022	Aug 2022	Sep 2022	Oct 2022	Nov 2022	Dec 2022
1		42.4 ^P	Ice ^P	38.7 ^P	143 ^P	33.6 ^P	16.7 ^P	5.74 ^P	3.33 ^P	2.39 ^P	4.08 ^P	9.20 ^P	55.7 ^P
2		61.8 ^P	19.6 ^P	41.0 ^P	74.2 ^P	33.4 ^P	17.9 ^P	11.2 ^P	3.45 ^P	2.22 ^P	3.98 ^P	9.60 ^P	30.1 ^P
3		46.6 ^P	30.8 ^P	43.6 ^P	46.8 ^P	37.6 ^P	17.5 ^P	8.40 ^P	3.25 ^P	2.18 ^P	3.69 ^P	9.09 ^P	45.7 ^P
4		36.3 ^P	Ice ^P	38.9 ^P	45.5 ^P	37.4 ^P	14.9 ^P	6.42 ^P	3.00 ^P	2.65 ^P	3.60 ^P	8.64 ^P	50.7 ^P
5		35.7 ^P	Ice ^P	35.2 ^P	39.8 ^P	35.8 ^P	12.0 ^P	5.81 ^P	2.94 ^P	6.25 ^P	35.0 ^P	8.33 ^P	32.7 ^P
6		37.8 ^P	Ice ^P	55.1 ^P	43.7 ^P	33.1 ^P	11.0 ^P	5.63 ^P	2.93 ^P	110 ^P	30.7 ^P	8.56 ^P	28.6 ^P
7		36.2 ^P	96.1 ^P	123 ^P	51.8 ^P	32.8 ^P	10.2 ^P	5.19 ^P	2.87 ^P	58.6 ^P	14.5 ^P	8.84 ^P	125 ^P
8		Ice ^P	44.7 ^P	132 ^P	538 ^P	30.0 ^P	15.5 ^P	4.94 ^P	2.94 ^P	20.9 ^P	8.91 ^P	8.37 ^P	71.4 ^P
9		Ice ^P	42.0 ^P	60.3 ^P	172 ^P	28.0 ^P	66.1 ^P	4.61 ^P	2.97 ^P	11.0 ^P	6.99 ^P	7.70 ^P	37.2 ^P
10	31.3 ^P	33.8 ^P	40.1 ^P	51.8 ^P	124 ^P	26.3 ^P	32.4 ^P	4.40 ^P	2.90 ^P	7.76 ^P	6.29 ^P	7.53 ^P	31.2 ^P
11	39.4 ^P	Ice ^P	42.6 ^P	59.5 ^P	79.8 ^P	25.5 ^P	19.8 ^P	4.14 ^P	2.61 ^P	6.14 ^P	5.82 ^P	11.6 ^P	

9. Populate the spreadsheet with the discharge rate. The Little Pond watershed discharge rate will be automatically calculated.

Date	Nepaug Area (sq mi)	Little Pond Outlet (sq. mi.)	Discharge Nepaug (ft ³ /sec)	Discharge Bantam Pond (ft ³ /sec)
10-Dec-22	23.4	25	31.2	33.33
	23.4	25		0.00
	23.4	25		0.00

10. Begin the estimation for the Bantam Lake Outlet by clicking that tab at the bottom of the spreadsheet and following the same steps as above.

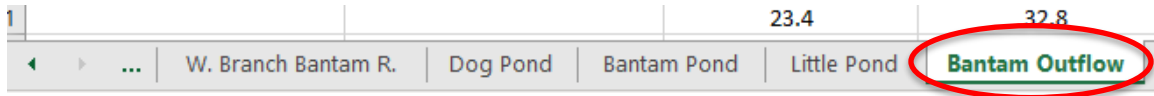

1				23.4		32.8		
	◀	▶	...	W. Branch Bantam R.	Dog Pond	Bantam Pond	Little Pond	Bantam Outflow

LABORATORY MINIMUM DETECTION LIMITS AND QUALITY CONTROLS AND ASSURANCES

It will be important and necessary to convey to the commercial laboratory providing analytical services the minimum detection limits desired for the project. Most commercial laboratories provide a variety of services, e.g., analysis of wastewater, of potable water, and surface water. Detection levels for wastewater are typically much higher than those needed for surface waters like lakes and stream courses.

Table 5 below provides minimum detection levels for analyses of water samples from Bantam Lake and other sites in the watershed.

Table 5. Minimum detection levels (MDL) for laboratory analyses.

Parameter	MDL in $\mu\text{g/L}$	MDL in mg/L
Total Phosphorus	5	0.005
Total Kjeldahl Nitrogen	5	0.005
Ammonia	5	0.005
Nitrate	50	0.050
Nitrite	50	0.050
Alkalinity	5000	5

Laboratory quality controls will include running a batch duplicate with each batch of ten samples and calculating the *Relative Percent Difference* (RPD). In addition, an analysis of the initial calibration verification will be performed to show that the calibration curve was within acceptable limits.

Laboratory controls will also include running a *Laboratory Control Sample* (LCS), sometimes referred to as a *Blank Spike* (BS) where reagent water (distilled water) is spike with a known concentration of an analyte to ensure that the concentration of the analyte can be recovered.

The laboratory will also run a *Matrix Spike Sample* (MSD) where a sample in the batch is spike to determine if the spiked analyte can be recovered.

Successful laboratories place much emphasis on *accuracy* – how much of a known quantity is recovered – and *precision* – how close successive analyses are to each other. *Relative Percent Difference* is a measure of precision obtained from the batch duplicates and the MS/MSD. Accuracy is determined by the LCS and MS.

REFERENCES

- Bell, M. 1985. The Face of Connecticut. State Geological and Natural History Survey of Connecticut. Bull. 110.
- Canavan RW, Siver PA. 1994. Chemical and physical properties of Connecticut lakes, with emphasis on regional geology. LAKE RESERV MANAGE. 10(2):175-188.
- Canavan RW, Siver PA. 1995. Connecticut Lakes: A study of the chemical and physical properties of fifty-six Connecticut Lakes. New London (CT): Connecticut College Arboretum.
- [CT DEEP] Connecticut Department of Energy and Environmental Protection. 2004. WATER QUALITY REPORT TO CONGRESS. https://portal.ct.gov/-/media/DEEP/water/water_quality_management/305b/2004305bpdf.pdf
- [CT DEEP] Connecticut Department of Energy and Environmental Protection. 2016. 2016 Integrated Water Quality Report. https://portal.ct.gov/-/media/DEEP/water/water_quality_management/305b/2016IWORFinalpdf.pdf
- [CT DEEP] Connecticut Department of Energy and Environmental Protection. 2016. 2016 INTEGRATED WATER QUALITY REPORT. https://portal.ct.gov/-/media/DEEP/water/water_quality_management/305b/2016IWORFinalpdf.pdf
- [CT DEEP] Connecticut Department of Energy and Environmental Protection. 2020. INTEGRATED WATER QUALITY REPORT. https://portal.ct.gov/-/media/DEEP/water/water_quality_management/305b/2020/2020IWORFinal.pdf
- [CT DEEP] Connecticut Department of Energy and Environmental Protection. 2021a. Connecticut Statewide Lake Nutrient Total Maximum Daily Load Core Document. https://portal.ct.gov/-/media/DEEP/water/watershed_management/BantamLake/CT-Statewide-Lake-Nutrient-TMDL_Core-FINAL.pdf
- [CT DEEP] Connecticut Department of Energy and Environmental Protection. 2021b. Appendix 1: Bantam Lake Watershed TMDL. https://portal.ct.gov/-/media/DEEP/water/watershed_management/BantamLake/FINAL-Bantam-TMDL-Appendix.pdf
- [CT DEEP] Connecticut Department of Energy and Environmental Protection. 2022. 2022 INTEGRATED WATER QUALITY REPORT. https://portal.ct.gov/-/media/DEEP/water/water_quality_management/305b/2022/IWQR-Final-2022.pdf
- Deevey ES Jr. 1940. Limnological studies in Connecticut. V. A contribution to regional limnology. AM J SCI. 238(10):717-741.
- Frink CR, Norvell WA. 1984. Chemical and physical properties of Connecticut lakes. New Haven (CT): Connecticut Agricultural Experiment Station. Bulletin 817. 180 pp

Healy DF and KP Kulp. 1995. Water Quality Characteristics of Selected Public Recreational Lakes and Pond in Connecticut. US Geological Survey Water-Resource Investigations Report 95-4098. 227pp.

Siver, P.A. 1993. Inferring lakewater specific conductivity with scaled chrysophytes. *Limnol. Oceanogr.* 38: 1480-1492

Siver PA & Marsicano LJ. 1996. Inferring lake trophic status using scaled chrysophytes. In: *Chrysophytes: Progress and New Horizons*. Kristiansen J, Cronberg G (eds) *Beihefte zur Nova Hedwigia* 114: 233-246

Stone, RJ, JP Schafer EH London, and WB Thompson. 1992. Surficial Materials Map of Connecticut. Prepared in cooperation with the State of Connecticut Department of Environmental Protection Geological and Natural History Survey.

http://cteco.uconn.edu/maps/state/Surficial_Materials_Map_of_Connecticut.pdf

APPENDIX A. SAMPLE BANTAM LAKE FIELD DATA SHEET

Site: _____

Date: _____

Site Max Depth _____

Time: _____

Secchi Disk Depth _____

Site Conditions / Weather

Depth	Temp. (°C)	Dissolved O ₂	% O ₂ Sat.	Cond.	SPC	pH
0.5						
1						
2						
3						
4						
5						
6						
7						
8						

APPENDIX B. SAMPLE CHAIN OF CUSTODY FOR BANTAM LAKE SAMPLES.

COMPANY NAME:																	TOTAL# OF B O T T L E S	
ADDRESS:				ANALYSES REQUESTED														
PROJECT NAME:			Invoice:												COMMENTS OR NOTES (PRESERVATION)			
PROJECT MANAGER:			Email:															
SAMPLER(S) NAME:			Ph:															
LAB ID (LAB USE ONLY)	CLIENT SAMPLE ID		TYPE*	COLLECTION DATE / TIME														
			SW															
			SW															
			SW															
			SW															
			SW															
			SW															
			SW															
SPECIAL INSTRUCTIONS/ NOTES;																		
*TYPE : SW = Surface Water				RELINQUISHED BY:				RECEIVED BY:				DATE		TIME		COMMENTS		